

# FB-6SQ

## INFRARED SENSOR EXIT BUTTON - NO TOUCH



### Product Features

- Durable high quality stainless steel faceplate with infrared induction.
- High sensitivity sensor for fast identification.
- Corrosion resistance PC plastic closure for high temperature.
- Easy installation, long lifespan.

### Technical Specifications

Model	FB-6SQ
Material	304 Stainless steel
Function	Touchless
Power	DC 12V-24V max
Output Contact	NO/NC/COM
Sensing Distance	<10 CM
Installation Mode	Surface Mount
Mechanical Life	500,000 tests
Operating Temp	-10°C ~+55°C
Suitable Humidity	0-95% (Relative humidity)
Dimensions	86L*86W*37H (mm)
Weight	100g

### Dimension

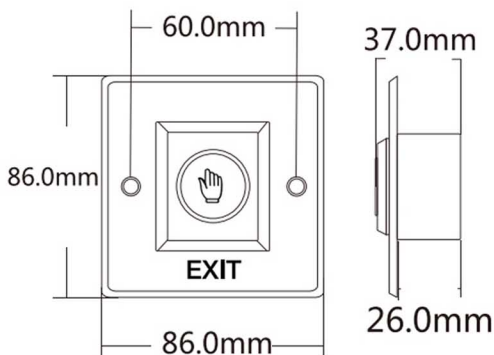

Blu-ray indication during standby



Green light indication during induction